



## Extinguishant Coincidence Unit

### Product Overview

- The Sigma XT+ ECD coincidence unit has two fully monitored inputs for connection to fire detection control equipment or addressable control modules to provide an EN12094-1 compliant extinguishant control system.
- Its many programmable features and extensive range of inputs and outputs make the Sigma XT+ ECD coincidence unit suitable for all extinguishing applications where a fully featured control device is required.
- Among the many features of the Sigma XT+ ECD are serially connected status units for reduced wiring and reduced installation cost, dual extinguishant outputs that may be configured for main/reserve applications and a countdown timer which displays the time until discharge of the extinguishant in seconds.
- All units are independently configurable via a simple, code based programming interface to suit the desired application.

### Features

- Complies with EN12094-1
- Dual extinguishant outputs
- First and second stage sounder outputs
- First and second stage relay contacts
- Main reserve facility
- Serial connection to status units
- Discharge countdown time indicator



Model No. K21001M2

## Example Schematic 1

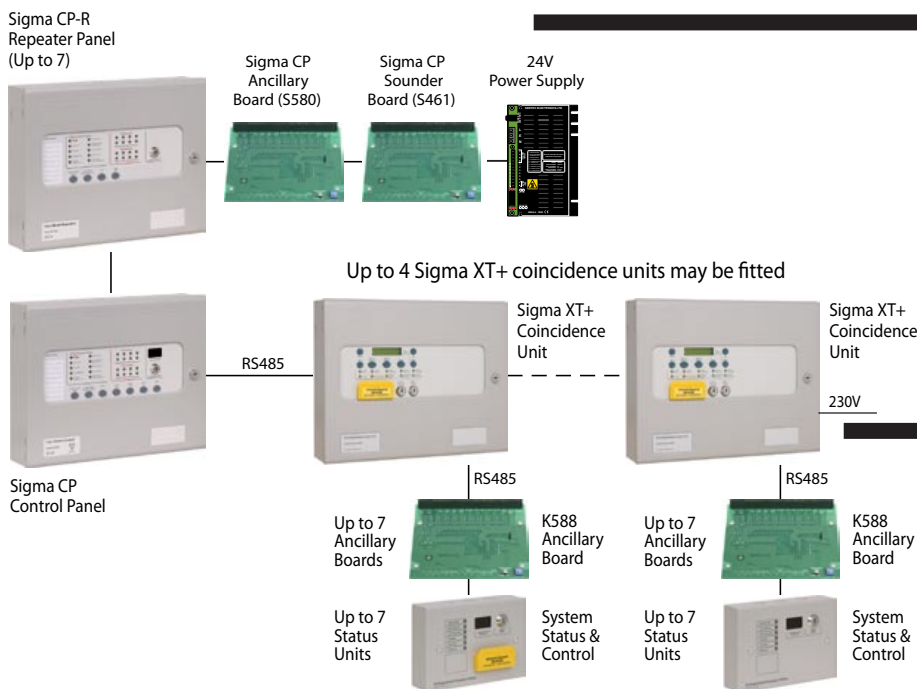

## Example Schematic 2

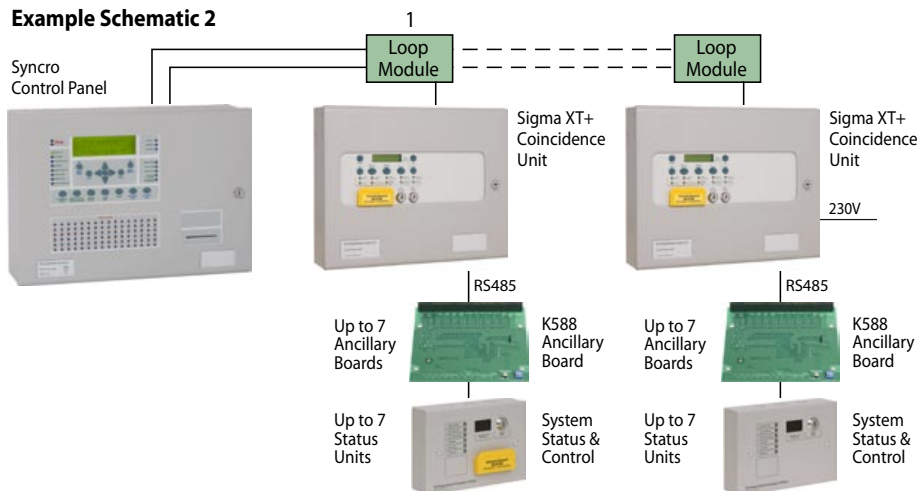

## Technical

<b>Product Code</b>	- K21001M2	<b>Local fire relay contact rating</b>	- 5 to 30VDC 1A Amp maximum for each
<b>Finish</b>	- Epoxy powder coated	<b>First stage contact rating</b>	- 5 to 30VDC 1A Amp maximum for each
<b>Colour - lid &amp; box</b>	- BS 00 A 05 grey - fine texture	<b>Second stage contact rating</b>	- 5 to 30VDC 1A Amp maximum for each
<b>Colour - controls plate &amp; labels</b>	- RAL 7047 light grey - satin	<b>Extract contact rating</b>	- 5 to 30VDC 1A Amp maximum for each
<b>Size</b>	- 385mm(W) x 310mm(H) x 90mm(D)	<b>Zone quiescent current</b>	- 0mA minimum, 2mA maximum
<b>Areas</b>	- 1	<b>Terminal capacity</b>	- 0.5mm <sup>2</sup> to 2.5mm <sup>2</sup> solid or stranded wire
<b>Mains supply</b>	- 230V AC, 50Hz +10% - 15% (100 Watts max.)	<b>Number of sounders per circuit</b>	- Dependent on type and current consumption
<b>Mains supply fuse</b>	- 1.6 Amp ( F1.6A L250V)	<b>Monitored input end of line</b>	- 6K8 +/- 5% ½ Watt resistor
<b>Power supply rating</b>	- 4 Amps total including battery charge 28V +/- 2V	<b>Sounder circuit end of line</b>	- 10K +/- 5% ¼ Watt resistor
<b>Power supply rating (K21083, K21084)</b>	- 4 Amps including battery charge 28V +/- 2V	<b>Extinguishant output end of line</b>	- 1N4004 Diode
<b>Maximum ripple current</b>	- 200 millivolts	<b>Extinguishant release output</b>	- 21 to 28V DC. Fused at 1 Amp
<b>Battery type (Yuasa NP)</b>	- 12 Volt sealed lead acid in series	<b>Extinguishant release delay</b>	- Adjustable 0 to 60 seconds (+/- 10%)
<b>Battery charge voltage</b>	- 27.6VDC nominal (temperature compensated)	<b>Extinguishant release duration</b>	- Adjustable 60 to 300 seconds
<b>Battery charge current</b>	- 0.7A maximum	<b>Monitored inputs normal threshold</b>	- (Allowable EOL) 10K ohm to 2K ohm
<b>Battery fuse</b>	- 20mm, 3.15A glass	<b>Monitored inputs alarm threshold</b>	- 2K ohms to 150 ohms +/- 5%
<b>Current draw in mains fail condition</b>	- 54 milliamps	<b>Monitored inputs Short circuit threshold</b>	- 140 ohms to 0 ohms +/- 5%
<b>Maximum current draw from batteries</b>	- 4 Amps	<b>Status unit/Ancillary board connection</b>	- Two wire RS485 connection (EIA-485 specification)
<b>Aux 24V output</b>	- Fused at 500mA with electronic fuse	<b>Status unit power output</b>	- 21 to 28V DC, Fused at 500mA with electronic fuse
<b>1st and 2nd stage Sounder outputs</b>	- 21 to 28V DC Fused at 1A with electronic fuse		
<b>Fault relay contact rating</b>	- 5 to 30VDC 1A Amp maximum for each		
<b>Fire relay contact rating</b>	- 5 to 30VDC 1A Amp maximum for each		